

指示がない限り、穴加工部分の寸法に別添の寸法許容差	0.5以上 6以下	±0.05
	6を超え 30以下	±0.1
	30を超え 120以下	±0.15
	120を超え 400以下	±0.2
	400を超え 1000以下	±0.3

For table clamping, connect air at a pressure of 0.3 to 0.5 MPa through a filter 40 μm or less. クランプ用エアは、40μm以下のフィルタを通した0.3~0.5MPaのエアを接続してください。

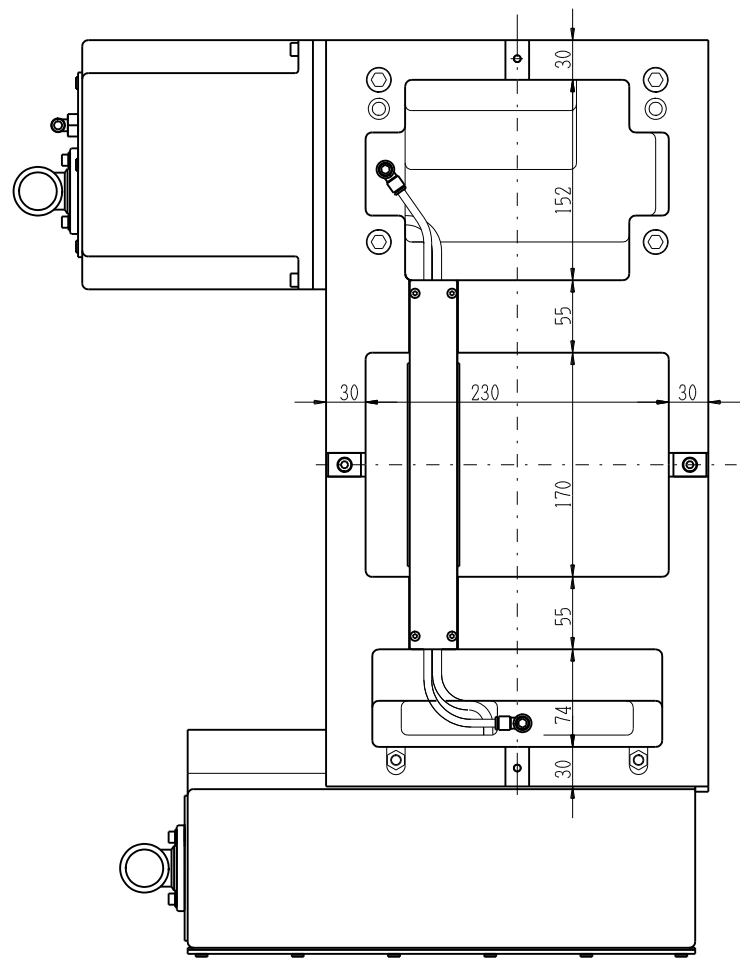

Air hydraulic part oil gauge  
エアハイドロ部 オイル窓

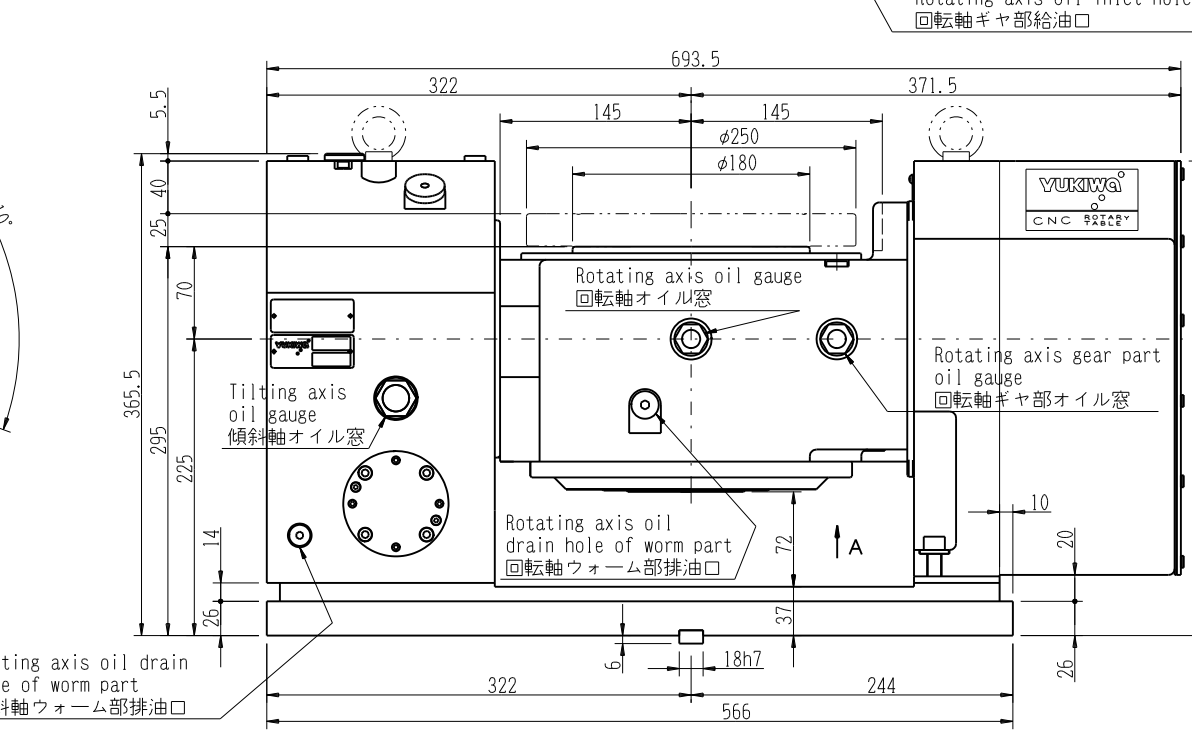
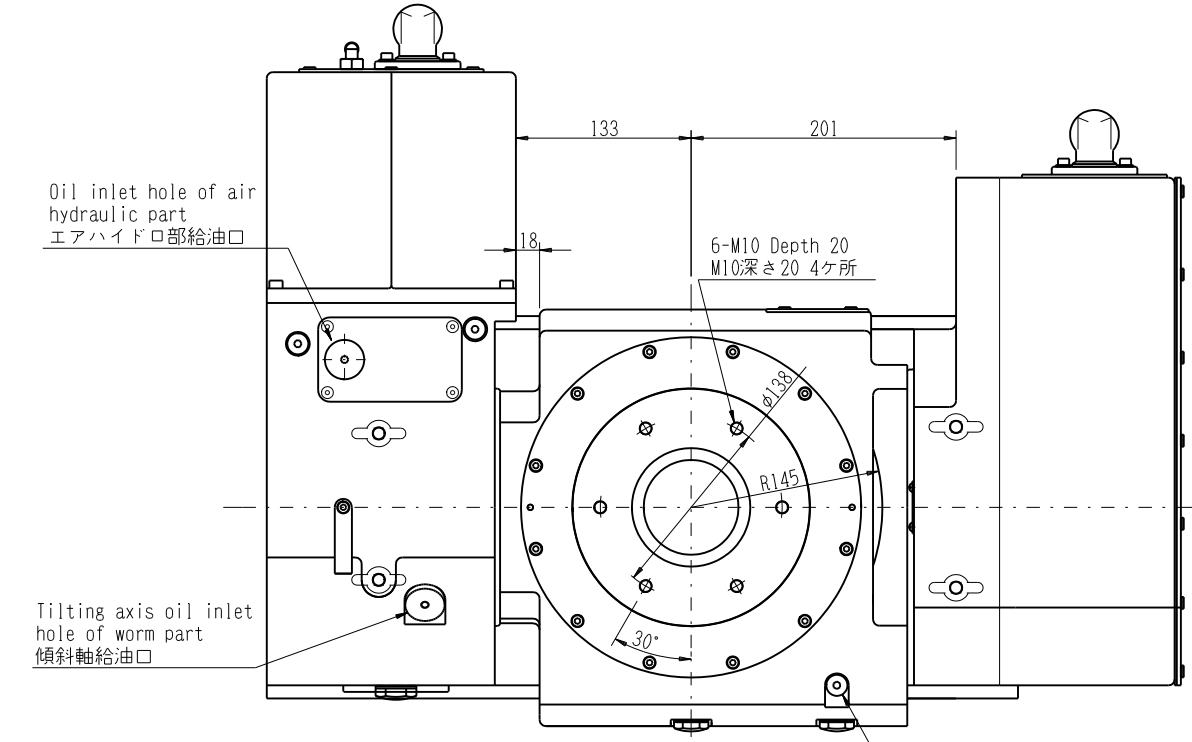
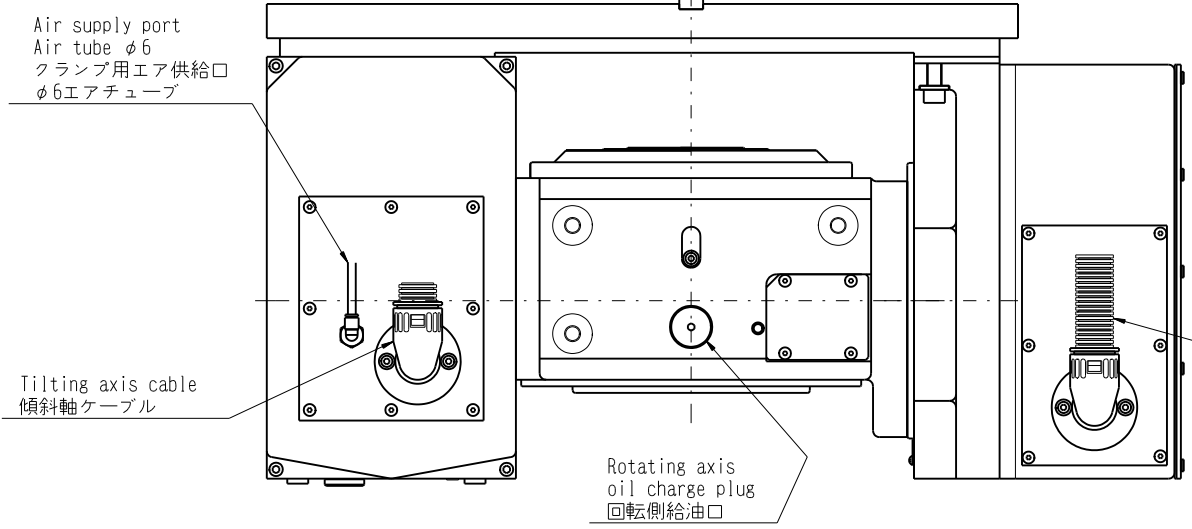
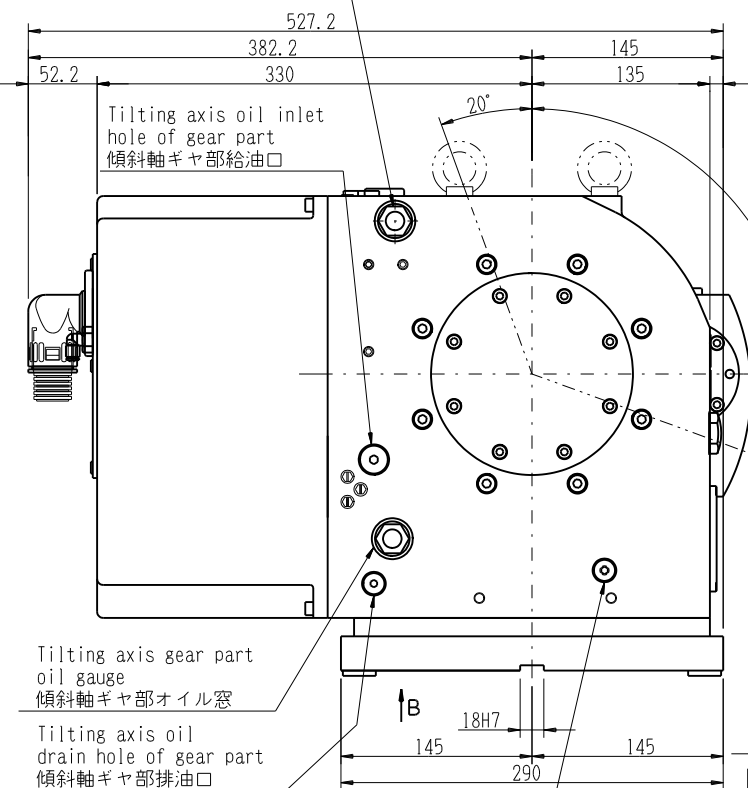

		Rotating axis 回転軸	Tilting axis 傾斜軸
AC servo motor ACサーボモータ	AC5-30A	R2AAB8100HXPGM SANYO	R2AAB8100HXPGM SANYO
Total reduction ratio 総合減速比		1/90	1/120
Max. number of revolutions テーブル最高回転数		22.2min <sup>-1</sup> (ε-22000min <sup>-1</sup> )	16.6min <sup>-1</sup> (ε-22000min <sup>-1</sup> )

Fixture M16 ...4 Sets  
(Standard accessories)  
取付金具 M16 ...4セット  
(標準付属品)

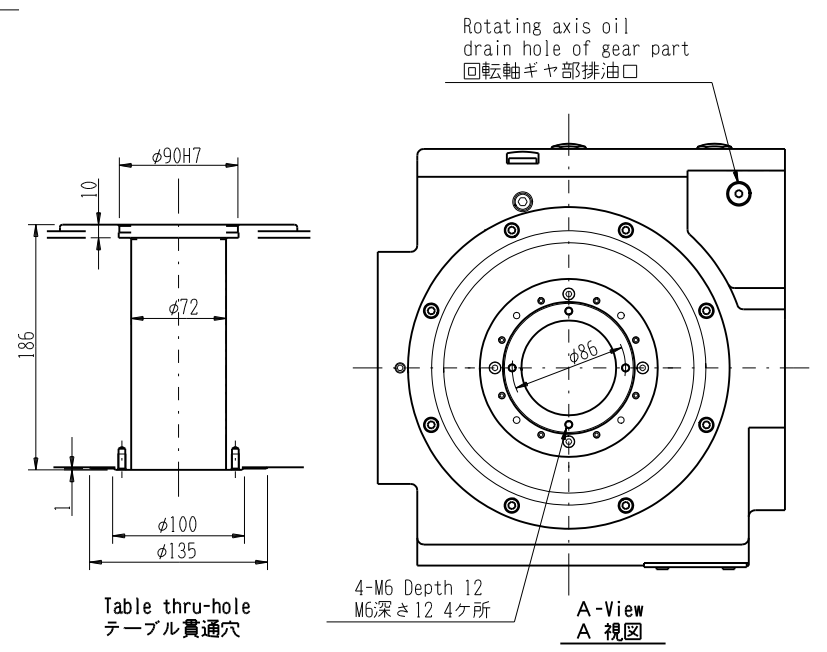
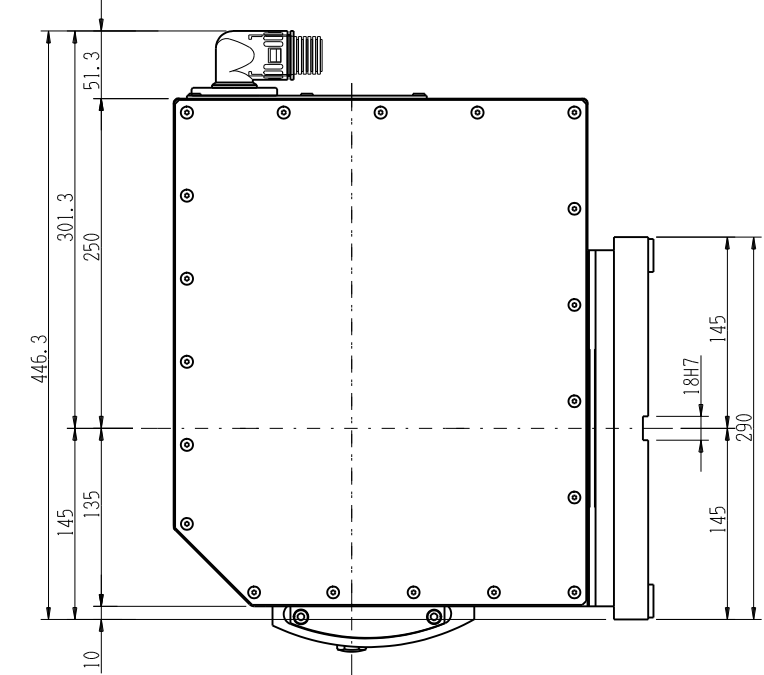
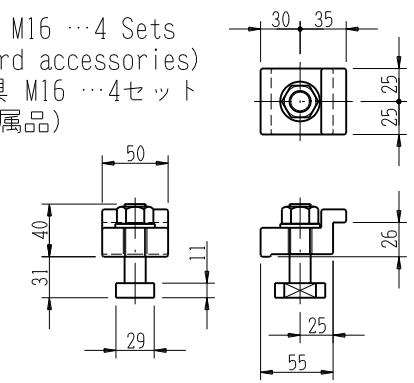

REVISION	DATE	NAME	HEAT TREAT.(熱処理)	APPROVED (承認)	CHECKED (審査)	DRAWN (製図)	PRODUCT NAME (製品名)	PART NAME (部品名)	MATERIAL (材質)	SCALE (尺度)
						18.5.21 小杉	CNC TILTING ROTARY TABLE CNC 傾斜円テーブル TNT250R Rotating axis: AC5-30A Tilting axis: AC5-30A	Outside drawing 外觀図		1/6
							YUKIWA SEIKO INC.		DWG. No. (図番)	TNT250R-D04-K1